

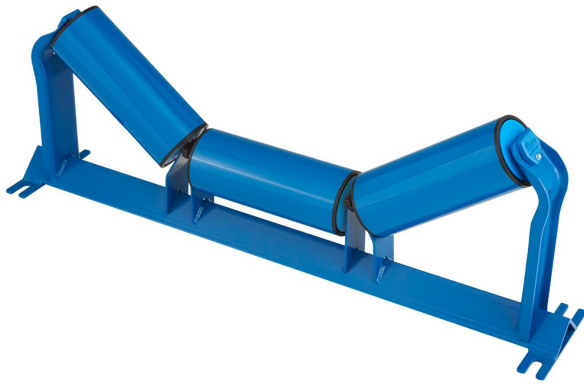

## Rodillos



### Rodillos

Los rodillos son intercambiables entre diferentes marcas y de fácil instalación.

El material con el que están elaborados ayuda a aumentar la vida útil del sistema, al reducir el mantenimiento y tiempo de inactividad.

**Serie CEMA:** B, C, D, E, F

**Diametro del rodo:** 4", 5", 6" and 7"

**Angulo:** 20°, 35°, 45°





**Ancho de banda:** 24", 30", 36", 42", 48", 54" and 60"

**Tipo de Rodamiento:** Cojinete Sellado

Troughing Idlers (Equal Roll)	Troughing Impact Idlers (Equal Roll)	Return Idlers	Rubber Disc Return Idler
Troughing Training Idlers (Equal Roll)	Return Training Idlers	Rubber Return Training Idlers	Troughing Unequal Idlers (Picking Idler)
Troughing Unequal Impact Idlers (Picking Idler)	Troughing Channel Insets Idler	Troughing Center Roll Offset Idler	

## Rodillos

### Roller Specification Guide

CEMA B	CEMA C	CEMA D	CEMA E	CEMA F
				
Diameter 4" 5"	Diameter 4" 5" 6"	Diameter 5" 6"	Diameter 6" 7"	Diameter 6" 7"
Shell Thickness .125"	Shell Thickness .125" (4" & 5") .188" (6")	Shell Thickness .188"	Shell Thickness .188" (6") .250" (7")	Shell Thickness .250"
Shell Options -	Shell Options -	Shell Options .250"	Shell Options .250" (6" DIA.)	Shell Options -
Sealed Bearing 6204 2RS-4" DIA. 6304 2RS-5" DIA.	Sealed Bearing 6005 2RS-4" DIA. 6205 2RS-5" DIA. 6305 2RS-6" DIA.	Sealed Bearing 6305 2RS	Sealed Bearing 6308 2RS-6" & 7" DIA.	Sealed Bearing 631-2RS
Shaft Diameter 20mm	Shaft Diameter 20mm (4") 25mm (5", 6" & Impacts)	Shaft Diameter 1.25" > 25mm 15" & below 25mm Shaft	Shaft Diameter 1.75" > 40mm (6" & 7")	Shaft Diameter 2.188" > 50mm
Poly-Shield INCLUDED (XS Available)	Poly-Shield INCLUDED (XS Available)	Poly-Shield INCLUDED (XS Available)	Poly-Shield & XS INCLUDED Standard (Steel) Optional (Impacts)	Poly-Shield & XS INCLUDED Non-Standard (Steel) Optional (Impacts)
Seal Arrangement Triple Labyrinth	Seal Arrangement Triple Labyrinth	Seal Arrangement Triple Labyrinth	Seal Arrangement Triple Labyrinth + Backseal Triple Labyrinth (Impacts)	Seal Arrangement Triple Labyrinth + Backseal Triple Labyrinth (Impacts)

## Rodillos

### Troughing Idler - Cema B (Equal Roll)

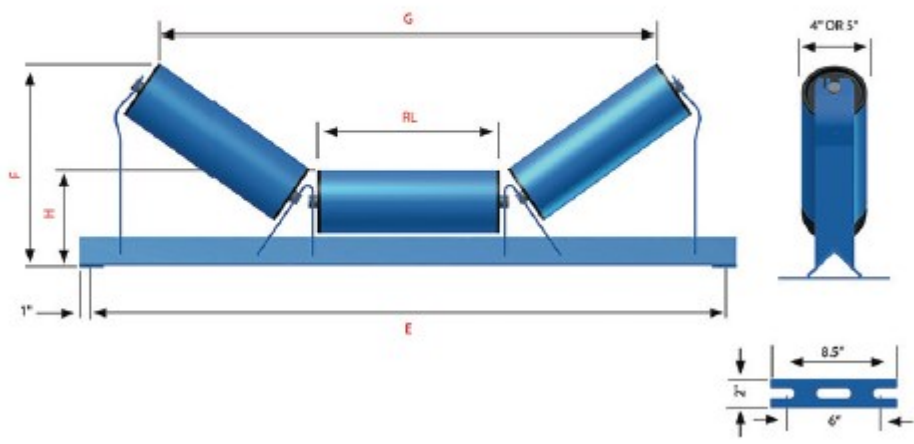

4 Inch Diameter - 20° Angle						
BELT	E	F	G	H	RL	WEIGHT
18"	27"	9.75"	21.688"	7.188"	6.75"	31 lbs
24"	33"	10.4375"	27.5"	7.188"	8.75"	36 lbs
30"	39"	11.063"	33.25"	7.188"	10.75"	45 lbs
36"	45"	11.75"	39"	7.188"	12.75"	51 lbs
42"	51"	12.5"	44.75"	7.25"	14.75"	74 lbs
48"	57"	13.813"	50.5"	7.25"	16.75"	84 lbs

4 Inch Diameter - 35° Angle						
BELT	E	F	G	H	RL	WEIGHT
18"	27"	11.25"	19.375"	7.188"	6.75"	33 lbs
24"	33"	12.4375"	24.688"	7.188"	8.75"	38 lbs
30"	39"	13.562"	29.9375"	7.188"	10.75"	47 lbs
36"	45"	14.688"	35.25"	7.188"	12.75"	53 lbs
42"	51"	15.875"	40.5"	7.25"	14.75"	76 lbs
48"	57"	17.063"	45.813"	7.25"	16.75"	86 lbs

5 Inch Diameter - 20° Angle						
BELT	E	F	G	H	RL	WEIGHT
18"	27"	10.188"	21.375"	7.688"	6.75"	35 lbs
24"	33"	10.875"	27.125"	7.688"	8.75"	41 lbs
30"	39"	11.562"	32.875"	7.688"	10.75"	51 lbs
36"	45"	12.25"	38.625"	7.688"	12.75"	57 lbs
42"	51"	13"	44.375"	7.75"	14.75"	81 lbs
48"	57"	13.625"	50.188"	7.75"	16.75"	92 lbs

5 Inch Diameter - 35° Angle						
BELT	E	F	G	H	RL	WEIGHT
18"	27"	11.625"	18.75"	7.688"	6.75"	37 lbs
24"	33"	12.813"	24.125"	7.688"	8.75"	43 lbs
30"	39"	14"	29.375"	7.688"	10.75"	53 lbs
36"	45"	15.125"	34.625"	7.688"	12.75"	60 lbs
42"	51"	16.3125"	39.9375"	7.75"	14.75"	83 lbs
48"	57"	17.4375"	45.188"	7.75"	16.75"	94 lbs



## Rodillos

### Troughing Idler - Cema C (Equal Roll)

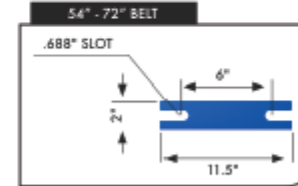
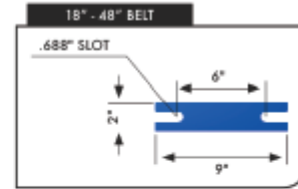
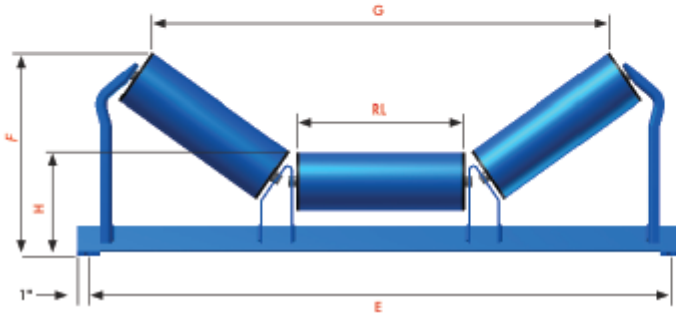

WIDE BASE FRAMES AVAILABLE  
(E DIMENSION) BELT + 15"

27.5" AVAILABLE

5 Inch Diameter - 20° Angle						
BELT	E	F	G	H	RL	WEIGHT
18"	27"	11.125"	21.75"	8.688"	6.75"	40 lbs
24"	33"	11.9375"	27.5"	8.688"	8.75"	46 lbs
30"	39"	12.562"	33.25"	8.75"	10.75"	58 lbs
36"	45"	13.3125"	39"	8.75"	12.75"	64 lbs
42"	51"	14"	44.75"	8.75"	14.75"	77 lbs
48"	57"	14.688"	50.5"	8.75"	16.75"	85 lbs
54"	63"	15.688"	56.3125"	9.3125"	18.75"	100 lbs
60"	69"	16.188"	62.063"	9.3125"	20.75"	108 lbs
72"	81"	17.688"	73.5"	9.3125"	24.75"	152 lbs

5 Inch Diameter - 35° Angle						
BELT	E	F	G	H	RL	WEIGHT
18"	27"	12.562"	18.875"	8.688"	6.75"	41 lbs
24"	33"	13.688"	24.125"	8.688"	8.75"	47 lbs
30"	39"	15"	29.375"	8.75"	10.75"	59 lbs
36"	45"	16.125"	34.688"	8.75"	12.75"	66 lbs
42"	51"	17.25"	39.938"	8.75"	14.75"	78 lbs
48"	57"	18.562"	45.25"	8.75"	16.75"	87 lbs
54"	63"	20.125"	50.5"	9.3125"	18.75"	103 lbs
60"	69"	21.25"	55.75"	9.3125"	20.75"	111 lbs
72"	81"	23.4375"	66.562"	9.3125"	24.75"	155 lbs

6 Inch Diameter - 20° Angle						
BELT	E	F	G	H	RL	WEIGHT
18"	27"	11.562"	21.5"	9.188"	6.75"	46 lbs
24"	33"	12.125"	27.25"	9.188"	8.75"	53 lbs
30"	39"	12.9375"	33"	9.25"	10.75"	65 lbs
36"	45"	13.813"	38.75"	9.25"	12.75"	73 lbs
42"	51"	14.562"	44.5"	9.25"	14.75"	88 lbs
48"	57"	15.25"	50.25"	9.25"	16.75"	96 lbs
54"	63"	16.063"	56"	9.813"	18.75"	112 lbs
60"	69"	16.625"	61.75"	9.813"	20.75"	121 lbs
72"	81"	18"	73.125"	9.813"	24.75"	165 lbs

6 Inch Diameter - 35° Angle						
BELT	E	F	G	H	RL	WEIGHT
18"	27"	12.75"	18.25"	9.188"	6.75"	47 lbs
24"	33"	14.125"	23.5"	9.188"	8.75"	54 lbs
30"	39"	15.3125"	28.813"	9.25"	10.75"	66 lbs
36"	45"	16.5"	34.125"	9.25"	12.75"	74 lbs
42"	51"	17.625"	39.375"	9.25"	14.75"	89 lbs
48"	57"	18.813"	44.625"	9.25"	16.75"	97 lbs
54"	63"	20.063"	49.9375"	9.813"	18.75"	115 lbs
60"	69"	21.25"	55.25"	9.813"	20.75"	124 lbs
72"	81"	23.625"	66"	9.813"	24.75"	169 lbs

## Rodillos

### Troughing Impact Idler - Cema B (Equal Roll)

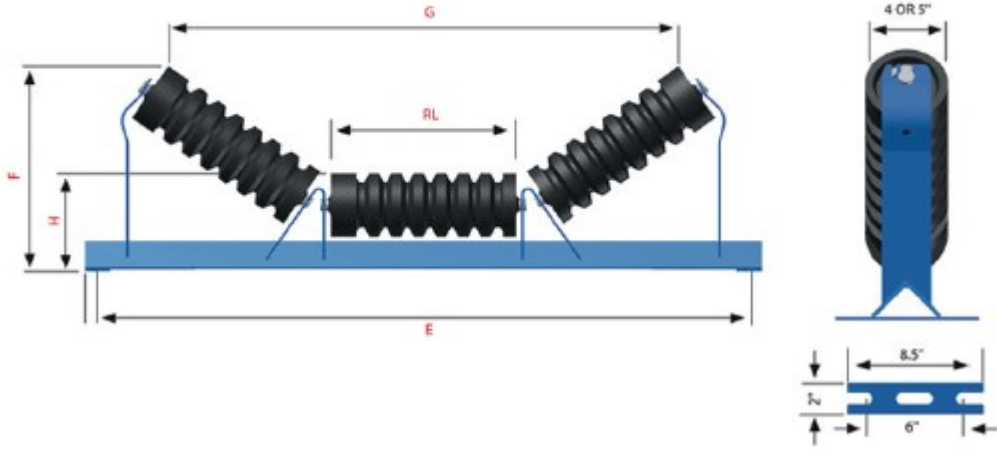

4 Inch Diameter - 20° Angle						
BELT	E	F	G	H	RL	WEIGHT
18"	27"	9.75"	21.5"	7.188"	6.125"	37 lbs
24"	33"	10.5"	27.25"	7.188"	8.125"	45 lbs
30"	39"	11.125"	33"	7.188"	10.125"	55 lbs
36"	45"	11.875"	38.75"	7.188"	12.125"	65 lbs
42"	51"	12.5"	44.5"	7.25"	14.125"	80 lbs
48"	57"	13.25"	50.25"	7.25"	16.125"	89 lbs

4 Inch Diameter - 35° Angle						
BELT	E	F	G	H	RL	WEIGHT
18"	27"	11.5"	19.25"	7.188"	6.125"	37 lbs
24"	33"	12.75"	24.5"	7.188"	8.125"	45 lbs
30"	39"	13.875"	29.75"	7.188"	10.125"	55 lbs
36"	45"	15"	35"	7.188"	12.125"	65 lbs
42"	51"	16.125"	40.375"	7.25"	14.125"	80 lbs
48"	57"	17.25"	45.625"	7.25"	16.125"	89 lbs

5 Inch Diameter - 20° Angle						
BELT	E	F	G	H	RL	WEIGHT
18"	27"	10.125"	20.375"	7.688"	6.5"	40 lbs
24"	33"	10.75"	26.125"	7.688"	8.5"	48 lbs
30"	39"	11.5"	32"	7.688"	10.5"	61 lbs
36"	45"	12.125"	37.75"	7.688"	12.5"	70 lbs
42"	51"	12.875"	43.5"	7.75"	14.5"	85 lbs
48"	57"	13.5"	49.25"	7.75"	16.5"	95 lbs

5 Inch Diameter - 35° Angle						
BELT	E	F	G	H	RL	WEIGHT
18"	27"	11.75"	18"	7.688"	6.5"	40 lbs
24"	33"	12.875"	23.25"	7.688"	8.5"	48 lbs
30"	39"	14"	28.5"	7.688"	10.5"	61 lbs
36"	45"	15.25"	33.875"	7.688"	12.5"	70 lbs
42"	51"	16.375"	39.125"	7.75"	14.5"	85 lbs
48"	57"	17.5"	45.375"	7.75"	16.5"	95 lbs



## Rodillos

### Troughing Impact Idler - Cema C (Equal Roll)

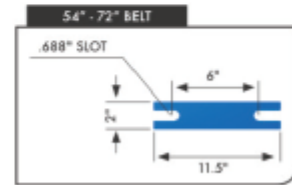
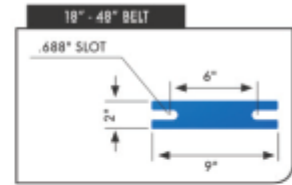
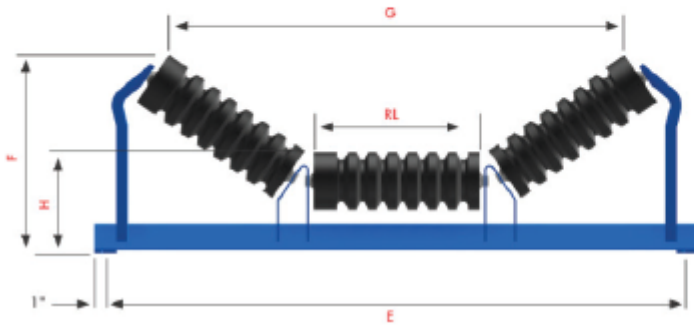

5 Inch Diameter - 20° Angle						
BELT	E	F	G	H	RL	WEIGHT
18"	27"	11.063"	21.625"	8.688"	6.5"	50 lbs
24"	33"	11.688"	27.375"	8.688"	8.5"	58 lbs
30"	39"	12.688"	33.125"	8.75"	10.5"	76 lbs
36"	45"	13.3125"	38.875"	8.75"	12.5"	85 lbs
42"	51"	14"	44.625"	8.75"	14.5"	101 lbs
48"	57"	14.688"	50.375"	8.75"	16.5"	113 lbs
54"		15.4375"	56.125"	9.3125"	18.5"	130 lbs
60"	69"	16.125"	61"	9.3125"	20.5"	142 lbs
72"	81"	17.5"	73.5"	9.3125"	24.5"	189 lbs

5 Inch Diameter - 35° Angle						
BELT	E	F	G	H	RL	WEIGHT
18"	27"	12.562"	18.75"	8.688"	6.5"	51 lbs
24"	33"	13.688"	24"	8.688"	8.5"	59 lbs
30"	39"	15"	29.25"	8.75"	10.5"	77 lbs
36"	45"	16"	34.5"	8.75"	12.5"	87 lbs
42"	51"	17.188"	39.75"	8.75"	14.5"	102 lbs
48"	57"	18.75"	45"	8.75"	16.5"	115 lbs
54"	63"	20.063"	50"	9.3125"	18.5"	133 lbs
60"	69"	21.25"	55.625"	9.3125"	20.5"	145 lbs
72"	81"	23.625"	66.562"	9.3125"	24.5"	192 lbs

6 Inch Diameter - 20° Angle						
BELT	E	F	G	H	RL	WEIGHT
18"	27"	11.562"	21.5"	9.188"	6.5"	54 lbs
24"	33"	12.813"	27"	9.188"	8.5"	65 lbs
30"	39"	13.563"	32.75"	9.25"	10.5"	84 lbs
36"	45"	14.25"	38.5"	9.25"	12.5"	95 lbs
42"	51"	14.9375"	44.25"	9.25"	14.5"	115 lbs
48"	57"	15.188"	50"	9.25"	16.5"	127 lbs
54"	63"	16.813"	55.75"	9.813"	18.5"	146 lbs
60"	69"	17.5"	61.5"	9.813"	20.5"	160 lbs
72"	81"	18.875"	73.125"	9.813"	24.5"	206 lbs

6 Inch Diameter - 35° Angle						
BELT	E	F	G	H	RL	WEIGHT
18"	27"	12.9375"	18.125"	9.188"	6.5"	55 lbs
24"	33"	14.063"	23.375"	9.188"	8.5"	66 lbs
30"	39"	15.375"	28.625"	9.25"	10.5"	85 lbs
36"	45"	16.9375"	34"	9.25"	12.5"	97 lbs
42"	51"	17.688"	39.25"	9.25"	14.5"	116 lbs
48"	57"	19.25"	44.5"	9.25"	16.5"	128 lbs
54"	63"	20.9375"	49.75"	9.813"	18.5"	148 lbs
60"	69"	21.625"	55"	9.813"	20.5"	162 lbs
72"	81"	24.3125"	66"	9.813"	24.5"	208 lbs



## Rodillos

### Return Idlers - Cema B

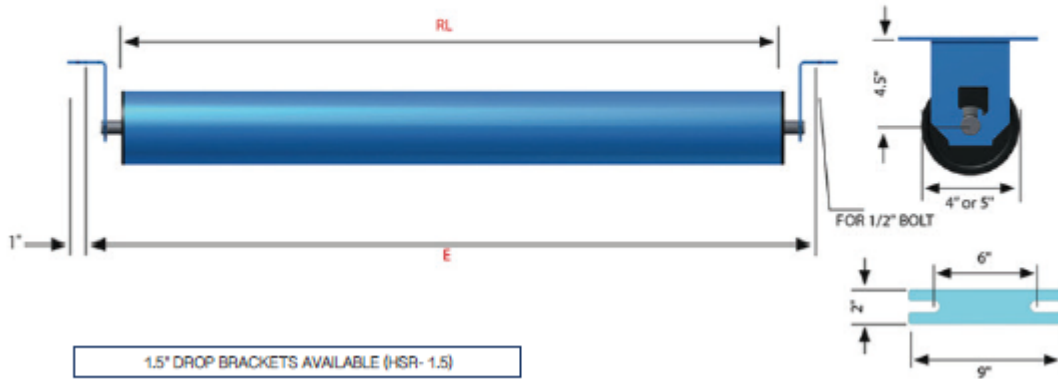

4 Inch Diameter			
BELT	E	RL	WEIGHT
18"	27"	21.75"	15 lbs
24"	33"	27.75"	18 lbs
30"	39"	33.75"	22 lbs
36"	45"	39.75"	25 lbs
42"	51"	45.75"	33 lbs
48"	57"	51.75"	37 lbs

5 Inch Diameter			
BELT	E	RL	WEIGHT
18"	27"	21.75"	18 lbs
24"	33"	27.75"	22 lbs
30"	39"	33.75"	26 lbs
36"	45"	39.75"	30 lbs
42"	51"	45.75"	37 lbs
48"	57"	51.75"	41 lbs



## Rodillos

### Return Idlers - Cema C



5 Inch Diameter			
BELT	E	RL	WEIGHT
18"	27"	21.75"	25 lbs
24"	33"	27.75"	29 lbs
30"	39"	33.75"	34 lbs
36"	45"	39.75"	38 lbs
42"	51"	45.75"	43 lbs
48"	57"	51.75"	47 lbs

6 Inch Diameter			
BELT	E	RL	WEIGHT
18"	27"	21.75"	29 lbs
24"	33"	27.75"	35 lbs
30"	39"	33.75"	40 lbs
36"	45"	39.75"	46 lbs
42"	51"	45.75"	51 lbs
48"	57"	51.75"	57 lbs





## Rodillos

### Rubber Disc Return Idler - Cema B

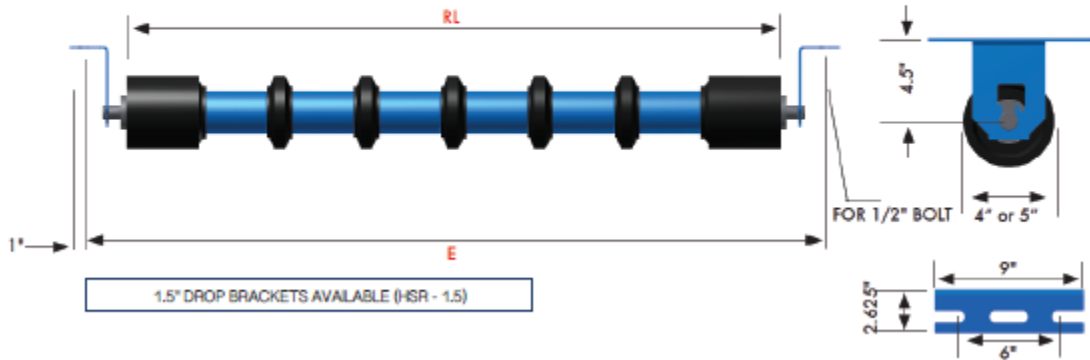

#### 4 Inch Diameter

BELT	E	RL	WEIGHT
18"	27"	21.75"	15 lbs
24"	33"	27.75"	18 lbs
30"	39"	33.75"	22 lbs
36"	45"	39.75"	25 lbs
42"	51"	45.75"	33 lbs
48"	57"	51.75"	37 lbs

#### 5 Inch Diameter

BELT	E	RL	WEIGHT
18"	27"	21.75"	18 lbs
24"	33"	27.75"	22 lbs
30"	39"	33.75"	26 lbs
36"	45"	39.75"	30 lbs
42"	51"	45.75"	37 lbs
48"	57"	51.75"	41 lbs



## Rodillos

### Rubber Disc Return Idler - Cema C

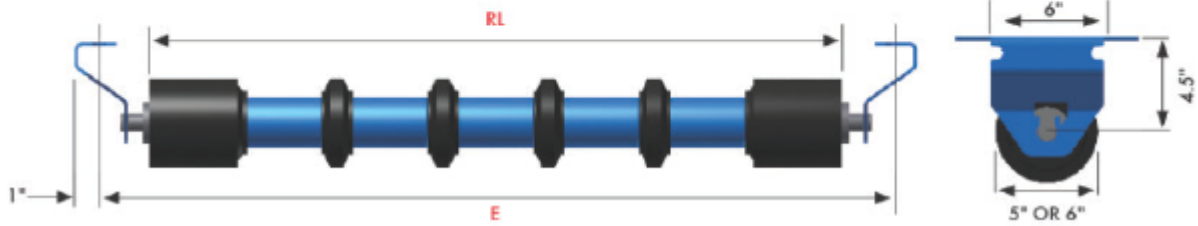

5 Inch Diameter			
BELT	E	RL	WEIGHT
18"	27"	21.75"	25 lbs
24"	33"	27.75"	29 lbs
30"	39"	33.75"	34 lbs
36"	45"	39.75"	38 lbs
42"	51"	45.75"	43 lbs
48"	57"	51.75"	47 lbs

6 Inch Diameter			
BELT	E	RL	WEIGHT
18"	27"	21.75"	29 lbs
24"	33"	27.75"	35 lbs
30"	39"	33.75"	40 lbs
36"	45"	39.75"	46 lbs
42"	51"	45.75"	51 lbs
48"	57"	51.75"	57 lbs



## Rodillos

### Trough Training Idler Cema B (Equal Roll)

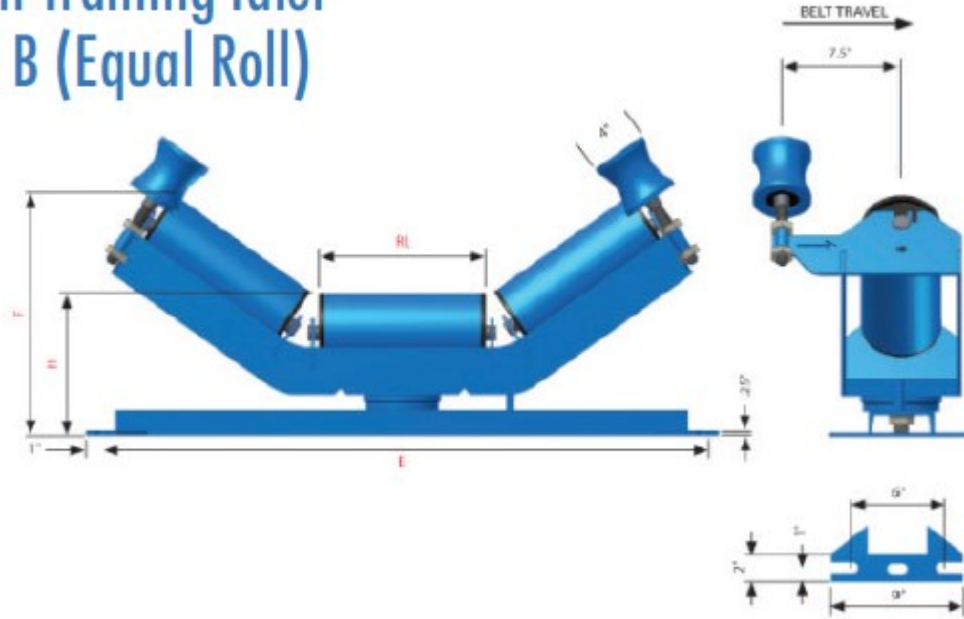

4 Inch Diameter - 20° Angle					
BELT	E	F	H	RL	WEIGHT
18"	27"	10.25"	8.25"	6.75"	61 lbs
24"	33"	11"	8.25"	8.75"	68 lbs
30"	39"	11.625"	8.25"	10.75"	84 lbs
36"	45"	12.375"	8.25"	12.75"	94 lbs

4 Inch Diameter - 35° Angle					
BELT	E	F	H	RL	WEIGHT
18"	27"	12"	8.25"	6.75"	64 lbs
24"	33"	13.25"	8.25"	8.75"	71 lbs
30"	39"	14.375"	8.25"	10.75"	88 lbs
36"	45"	15.5"	8.25"	12.75"	98 lbs

5 Inch Diameter - 20° Angle					
BELT	E	F	H	RL	WEIGHT
18"	27"	10.75"	8.75"	6.75"	65 lbs
24"	33"	11.5"	8.75"	8.75"	73 lbs
30"	39"	12.125"	8.75"	10.75"	90 lbs
36"	45"	12.875"	8.75"	12.75"	100 lbs
42"	51"	13.5"	8.75"	14.75"	114 lbs
48"	57"	14.25"	8.75"	16.75"	121 lbs

5 Inch Diameter - 35° Angle					
BELT	E	F	H	RL	WEIGHT
18"	27"	12.5"	8.75"	6.75"	68 lbs
24"	33"	13.5"	8.75"	8.75"	76 lbs
30"	39"	14.75"	8.75"	10.75"	94 lbs
36"	45"	15.875"	8.75"	12.75"	104 lbs
42"	51"	17"	8.75"	14.75"	115 lbs
48"	57"	18.125"	8.75"	16.75"	123 lbs



## Rodillos

### Trough Training Idler - Cema C (Equal Roll)

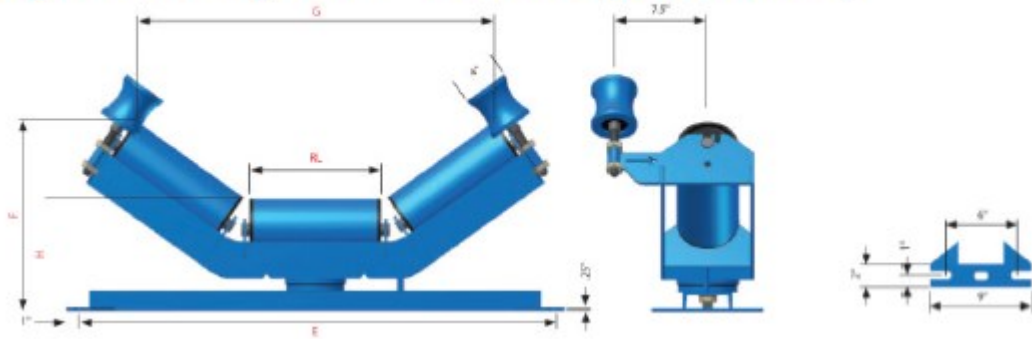

5 Inch Diameter - 20° Angle						
BELT	E	F	G	H	RL	WEIGHT
18"	27"	11.813"	21.75"	9.25"	6.75"	70 lbs
24"	33"	12.5"	27.5"	9.25"	8.75"	79 lbs
30"	39"	13.188"	33.25"	9.25"	10.75"	93 lbs
36"	45"	13.813"	39"	9.25"	12.75"	102 lbs
42"	51"	14.625"	44.75"	9.375"	14.75"	116 lbs
48"	57"	15.3125"	50.5"	9.375"	16.75"	123 lbs
54"	63"	16.375"	56.25"	9.813"	18.75"	144 lbs
60"	69"	17.063"	62"	9.813"	20.75"	154 lbs
72"	81"	18.5"	73.5"	9.813"	24.75"	202 lbs

5 Inch Diameter - 35° Angle						
BELT	E	F	G	H	RL	WEIGHT
18"	27"	13.25"	19"	9.25"	6.75"	71 lbs
24"	33"	14.4325"	24.25"	9.25"	8.75"	80 lbs
30"	39"	15.563"	29.5"	9.25"	10.75"	94 lbs
36"	45"	16.75"	34.75"	9.25"	12.75"	103 lbs
42"	51"	17.9375"	40"	9.375"	14.75"	117 lbs
48"	57"	19.063"	45.25"	9.375"	16.75"	124 lbs
54"	63"	20.625"	50.5"	9.813"	18.75"	145 lbs
60"	69"	21.75"	55.75"	9.813"	20.75"	156 lbs
72"	81"	24.063"	66.4375"	9.813"	24.75"	204 lbs

6 Inch Diameter - 20° Angle						
BELT	E	F	G	H	RL	WEIGHT
18"	27"	12.25"	21.375"	9.75"	6.75"	77 lbs
24"	33"	12.9375"	27.125"	9.75"	8.75"	86 lbs
30"	39"	13.625"	33.875"	9.75"	10.75"	101 lbs
36"	45"	14.3125"	38.625"	9.75"	12.75"	111 lbs
42"	51"	15.063"	44.375"	9.875"	14.75"	127 lbs
48"	57"	15.75"	50.125"	9.875"	16.75"	138 lbs
54"	63"	16.875"	55.875"	10.3125"	18.75"	156 lbs
60"	69"	17.563"	61.625"	10.3125"	20.75"	167 lbs
72"	81"	18.9375"	73.188"	10.3125"	24.75"	215 lbs

6 Inch Diameter - 35° Angle						
BELT	E	F	G	H	RL	WEIGHT
18"	27"	13.688"	18.5"	9.75"	6.75"	78 lbs
24"	33"	14.813"	23.75"	9.75"	8.75"	87 lbs
30"	39"	15.9375"	29"	9.75"	10.75"	102 lbs
36"	45"	17.125"	34.25"	9.75"	12.75"	112 lbs
42"	51"	18.375"	39.5"	9.875"	14.75"	128 lbs
48"	57"	19.5"	44.75"	9.875"	16.75"	139 lbs
54"	63"	21.063"	50"	10.3125"	18.75"	157 lbs
60"	69"	22.25"	55.25"	10.3125"	20.75"	168 lbs
72"	81"	24.5"	65.813"	10.3125"	24.75"	216 lbs



## Rodillos

### Return Training Idlers - Cema B

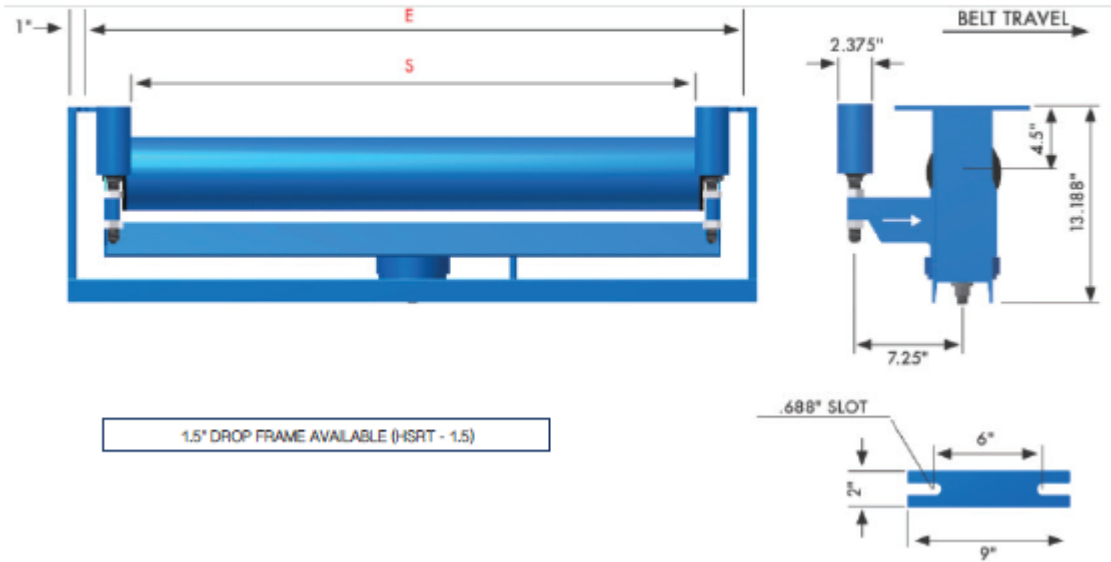

4 Inch Diameter			
BELT	E	S	WEIGHT
18"	27"	20"	59 lbs
24"	33"	26"	66 lbs
30"	39"	32"	84 lbs
36"	45"	38"	93 lbs

5 Inch Diameter			
BELT	E	S	WEIGHT
18"	27"	20"	62 lbs
24"	33"	26"	70 lbs
30"	39"	32"	88 lbs
36"	45"	38"	98 lbs
42"	51"	44"	103 lbs
48"	57"	50"	110 lbs



## Rodillos

### Return Training Idlers - Cema C

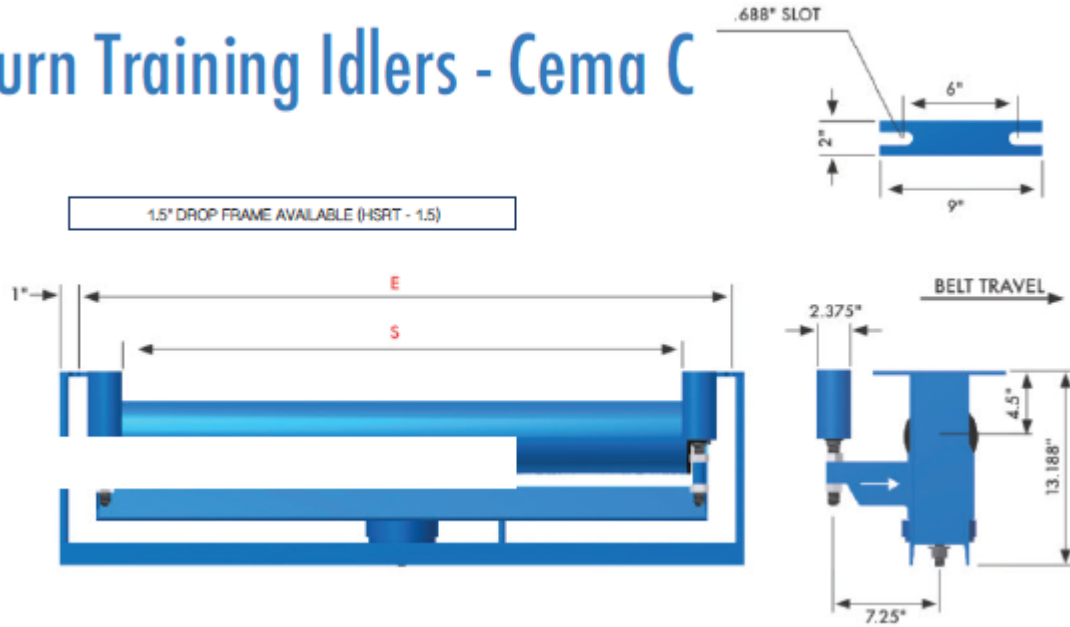

1.5' DROP FRAME AVAILABLE (HSRT - 1.5)

5 Inch Diameter			
BELT	E	S	WEIGHT
18"	27"	20.3125"	69 lbs
24"	33"	26.3125"	77 lbs
30"	39"	32.3215"	90 lbs
36"	45"	38.3125"	99 lbs
42"	51"	44.3125"	114 lbs
48"	57"	50.3125"	124 lbs

6 Inch Diameter			
BELT	E	S	WEIGHT
18"	27"	20.3125"	73 lbs
24"	33"	26.3125"	83 lbs
30"	39"	32.3215"	96 lbs
36"	45"	38.3125"	107 lbs
42"	51"	44.3125"	122 lbs
48"	57"	50.3125"	134 lbs



## Rodillos

### Rubber Return Training Idlers - Cema B

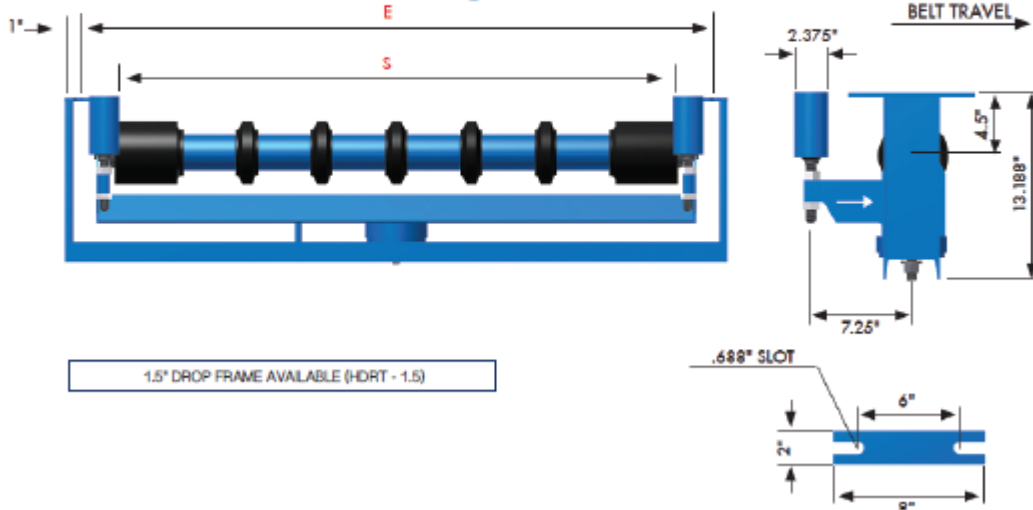

4 Inch Diameter		
BELT	E	S
18"	27"	20"
24"	33"	26"
30"	39"	32"
36"	45"	38"
42"	51"	44"
48"	57"	50"

5 Inch Diameter			
BELT	E	S	WEIGHT
18"	27"	20"	65 lbs
24"	33"	26"	74 lbs
30"	39"	32"	93 lbs
36"	45"	38"	104 lbs
42"	51"	44"	127 lbs
48"	57"	50"	140 lbs



INSER

## Rodillos

### Rubber Return Training Idlers - Cema C

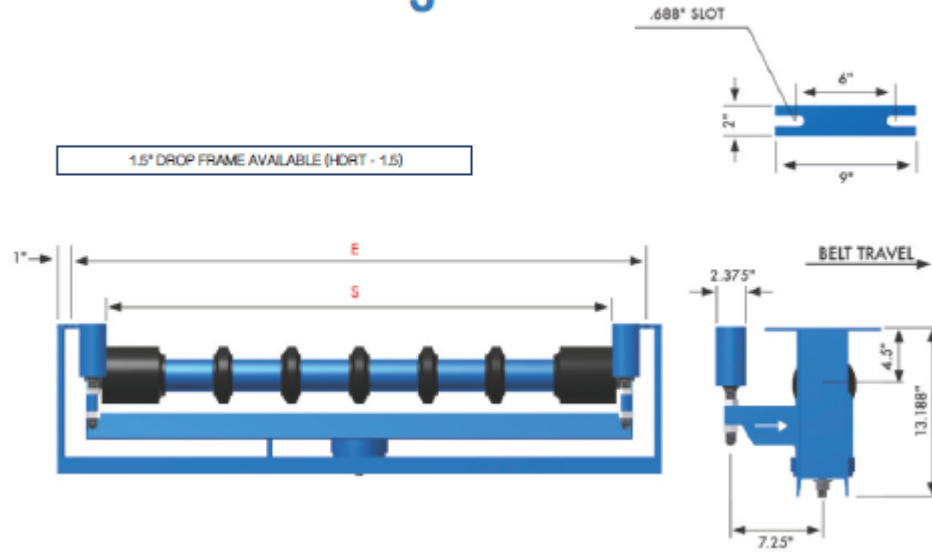

5 Inch Diameter			
BELT	E	S	WEIGHT
18"	27"	20.3125*	72 lbs
24"	33"	26.3125*	81 lbs
30"	39"	32.3215*	94 lbs
36"	45"	38.3125*	104 lbs
42"	51"	44.3125*	119 lbs
48"	57"	50.3125*	130 lbs

6 Inch Diameter			
BELT	E	S	WEIGHT
18"	27"	20.3125*	76 lbs
24"	33"	26.3125*	85 lbs
30"	39"	32.3215*	99 lbs
36"	45"	38.3125*	110 lbs
42"	51"	44.3125*	125 lbs
48"	57"	50.3125*	137 lbs





## Rodillos

### Troughing Unequal Idlers - Cema C

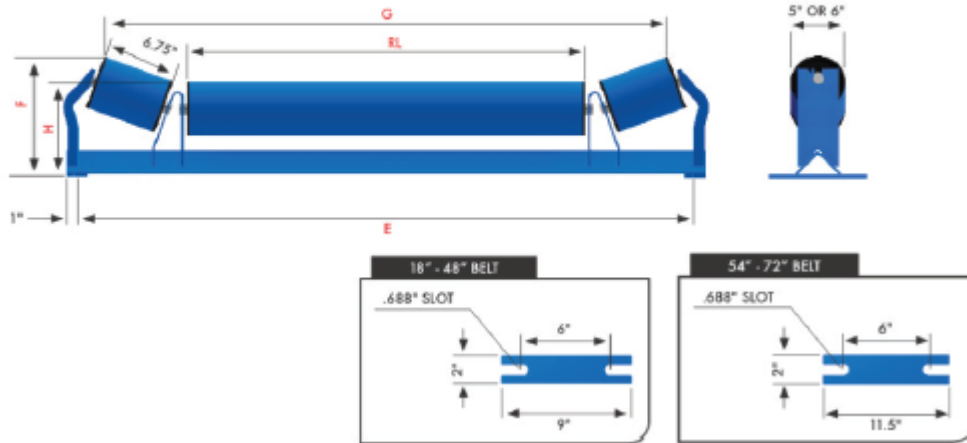

5 Inch Diameter - 20° Angle						
BELT	E	F	G	H	RL	WEIGHT
24"	33"	10.9375"	27.375"	8.688"	12.75"	46 lbs
30"	39"	11"	33.375"	8.75"	18.75"	58 lbs
36"	45"	11"	39.375"	8.75"	24.75"	64 lbs
42"	51"	11.063"	45.375"	8.75"	30.75"	77 lbs
48"	57"	11.063"	51.375"	8.75"	36.75"	85 lbs

5 Inch Diameter - 35° Angle						
BELT	E	F	G	H	RL	WEIGHT
24"	33"	12.5"	24.875"	8.688"	12.75"	47 lbs
30"	39"	12.562"	30.875"	8.75"	18.75"	58 lbs
36"	45"	12.562"	36.875"	8.75"	24.75"	65 lbs
42"	51"	12.625"	42.875"	8.75"	30.75"	77 lbs
48"	57"	12.625"	48.875"	8.75"	36.75"	87 lbs

6 Inch Diameter - 20° Angle						
BELT	E	F	G	H	RL	WEIGHT
24"	33"	11.4375"	27"	9.188"	12.75"	53 lbs
30"	39"	11.5"	33"	9.25"	18.75"	65 lbs
36"	45"	11.5"	39"	9.25"	24.75"	73 lbs
42"	51"	11.562"	45"	9.25"	30.75"	86 lbs
48"	57"	11.562"	51"	9.25"	36.75"	97 lbs

6 Inch Diameter - 35° Angle						
BELT	E	F	G	H	RL	WEIGHT
24"	33"	12.9375"	24.25"	9.188"	12.75"	54 lbs
30"	39"	13"	30.25"	9.25"	18.75"	66 lbs
36"	45"	13"	36.25"	9.25"	24.75"	74 lbs
42"	51"	13.063"	42.25"	9.25"	30.75"	87 lbs
48"	57"	13.063"	48.25"	9.25"	36.75"	98 lbs



## Rodillos

### Troughing Channel Insets Idler - Cema B (also available in Cema C & D and Impacts)



4 Inch Diameter - 20° Angle			
E	F	H	WEIGHT
23.625"	7.562"	5.125"	33 lbs
29.625"	7.688"	5.125"	36 lbs
35.625"	8.375"	5.125"	41 lbs
41.625"	9.063"	5.125"	47 lbs
47.625"	9.75"	5.125"	51 lbs
53.625"	9.75"	5.125"	57 lbs

4 Inch Diameter - 35° Angle			
E	F	H	WEIGHT
23.625"	9.063"	5.125"	34 lbs
29.625"	9.063"	5.125"	38 lbs
35.625"	10.188"	5.125"	43 lbs
41.625"	11.313"	5.125"	50 lbs
47.625"	12.5"	5.125"	53 lbs
53.625"	12.5"	5.125"	59 lbs

5 Inch Diameter - 20° Angle			
E	F	H	WEIGHT
23.625"	7.688"	5.688"	37 lbs
29.625"	8.125"	5.688"	41 lbs
35.625"	8.813"	5.688"	47 lbs
41.625"	9.5"	5.688"	54 lbs
47.625"	10.188"	5.688"	60 lbs
53.625"	10.188"	5.688"	66 lbs
59.625"	10.188"	5.688"	89 lbs
65.625"	10.875"	5.688"	98 lbs

5 Inch Diameter - 35° Angle			
E	F	H	WEIGHT
23.625"	9.562"	5.688"	38 lbs
29.625"	9.563"	5.688"	42 lbs
35.625"	10.688"	5.688"	49 lbs
41.625"	11.813"	5.688"	56 lbs
47.625"	13"	5.688"	62 lbs
53.625"	13"	5.688"	69 lbs
59.625"	13"	5.688"	91 lbs
65.625"	14.125"	5.688"	101 lbs



## Rodillos

### Troughing Center Roll Offset Idler- Cema C

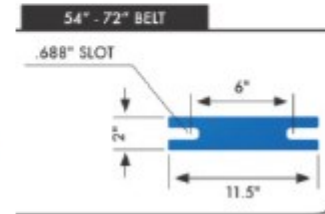
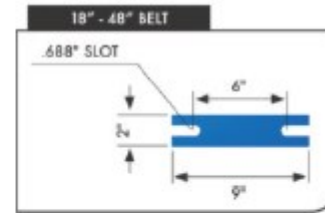
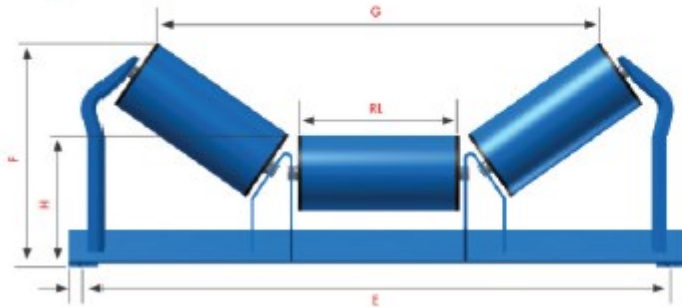

5 Inch Diameter - 20° Angle						
BELT	E	F	G	H	RL	WEIGHT
18"	27"	11.125"	21.75"	8.688"	6.75"	41 lbs
24"	33"	11.9375"	27.5"	8.688"	8.75"	47 lbs
30"	39"	12.562"	33.25"	8.75"	10.75"	59 lbs
36"	45"	13.3125"	39"	8.75"	12.75"	65 lbs
42"	51"	14"	44.75"	8.75"	14.75"	78 lbs
48"	57"	14.688"	50.5"	8.75"	16.75"	86 lbs
54"	63"	15.688"	56.312"	9.3125"	18.75"	101 lbs
60"	69"	16.188"	62.063"	9.3125"	20.75"	109 lbs
72"	81"	17.688"	71.5"	9.3125"	24.75"	148 lbs

5 Inch Diameter - 35° Angle						
BELT	E	F	G	H	RL	WEIGHT
18"	27"	12.562"	18.875"	8.688"	6.75"	43 lbs
24"	33"	13.688"	24.125"	8.688"	8.75"	49 lbs
30"	39"	15"	29.375"	8.75"	10.75"	61 lbs
36"	45"	16.125"	34.688"	8.75"	12.75"	67 lbs
42"	51"	17.25"	39.9375"	8.75"	14.75"	80 lbs
48"	57"	18.562"	45.25"	8.75"	16.75"	88 lbs
54"	63"	20.125"	50.5"	9.3125"	18.75"	104 lbs
60"	69"	21.25"	55.75"	9.3125"	20.75"	112 lbs
72"	81"	23.4375"	65.5"	9.3125"	24.75"	151 lbs

6 Inch Diameter - 20° Angle						
BELT	E	F	G	H	RL	WEIGHT
18"	27"	11.562"	21.5"	9.188"	6.75"	47 lbs
24"	33"	12.125"	27.25"	9.188"	8.75"	54 lbs
30"	39"	12.9375"	33"	9.25"	10.75"	66 lbs
36"	45"	13.813"	38.75"	9.25"	12.75"	74 lbs
42"	51"	14.562"	44.5"	9.25"	14.75"	89 lbs
48"	57"	15.25"	50.25"	9.25"	16.75"	97 lbs
54"	63"	16.063"	56"	9.813"	18.75"	113 lbs
60"	69"	16.625"	61.75"	9.813"	20.75"	122 lbs
72"	81"	18"	71.125"	9.813"	24.75"	161 lbs

6 Inch Diameter - 35° Angle						
BELT	E	F	G	H	RL	WEIGHT
18"	27"	12.75"	18.25"	9.188"	6.75"	49 lbs
24"	33"	14.125"	23.5"	9.188"	8.75"	56 lbs
30"	39"	15.3125"	28.813"	9.25"	10.75"	68 lbs
36"	45"	16.5"	34.125"	9.25"	12.75"	76 lbs
42"	51"	17.625"	39.375"	9.25"	14.75"	91 lbs
48"	57"	18.813"	44.625"	9.25"	16.75"	99 lbs
54"	63"	20.063"	49.938"	9.813"	18.75"	116 lbs
60"	69"	21.25"	55.25"	9.813"	20.75"	125 lbs
72"	81"	23.625"	64.9375"	9.813"	24.75"	164 lbs